

Front Panel Display



[Photo] Front Panel Display Sample

Monitor data can be saved for over 10 years in any SD card on the market. (Data of currents, voltages, temperatures, forward power and reverse power)

R&K warrants amplifiers equipped with new display panel for a period of 3.5 years.

Saved data can be viewed by LCD or TFT at anytime.

Easy-to-read bright colored display (large type/small type)

By using GPIB/RS232 interface, ON/OFF, BAND switching can be controlled by command input through computer.

Easy-to-read bright colored display (large type/small type)

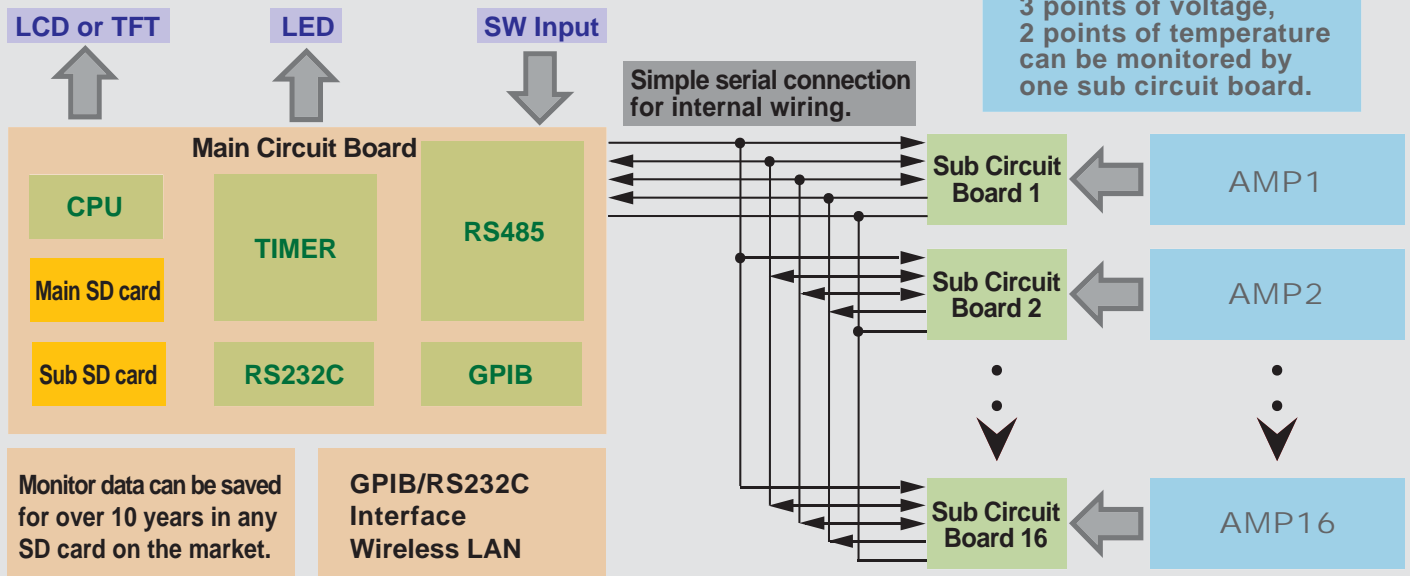

*NOTE: All the details such as what time and what date the power was switched on, value of forward power, reverse power, currents, voltages, temperature and TTL are all recorded and saved. All the data can be email to R&K for diagnoses when necessary.