

POWER AMPLIFIER



R&K-CGA11424BW200-5757R(P)

- X-Band All Solid State Amplifier
- Broadband Frequency : 11.424GHz ± 0.1GHz
- Output Power : 400W (min.) @ Pulse
- With Output Circulator

SPECIFICATIONS @ +25°C

Frequency Range	: 11.424GHz ± 100MHz
Small Signal Gain	: +57.0dB (min.)
Gain Flatness	: ±0.7dB (max.)
Output Power	: 400W (min.) @ 11.424GHz, Pulse
Operation Mode	: Class AB
Harmonics	: -40.0dBc (max.) @ Po=400W
Spurious	: -65.0dBc (max.) @ Po=400W
Impedance	: 50Ω
Input Return Loss	: -18.0dB (max.)
Output Return Loss	: -14.0dB (max.)
Maximum RF Input Power	: +3.0dBm
AC Supply Input	: AC100V ± 10% / 1φ, 50/60Hz, 1kVA
Operating Temperature	: 0°C to +40°C
Storage Temperature	: -15°C to +65°C
Connectors	: RF - IN N - FEMALE RF - OUT N - FEMALE
Size	: (W)480mm × (D)600mm × (H)221.5mm
Weight	: 75.0kg (max.)
Cooling	: Forced Air Cooling and Water Cooling
Protection Circuits	: Over Temperature Protection Power Supply Voltage Protection Output Over Power Protection Output Over Reflection Power Protection
Other	: With Output Circulator

OUTLINE DRAWING

※ IN MILLIMETERS

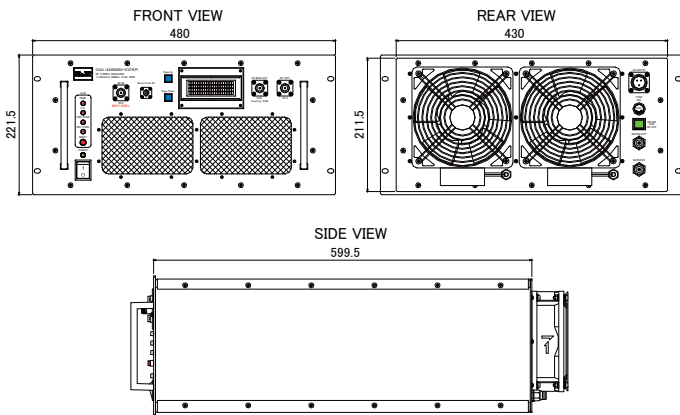

TYPICAL PERFORMANCE (Temp @ +25°C)

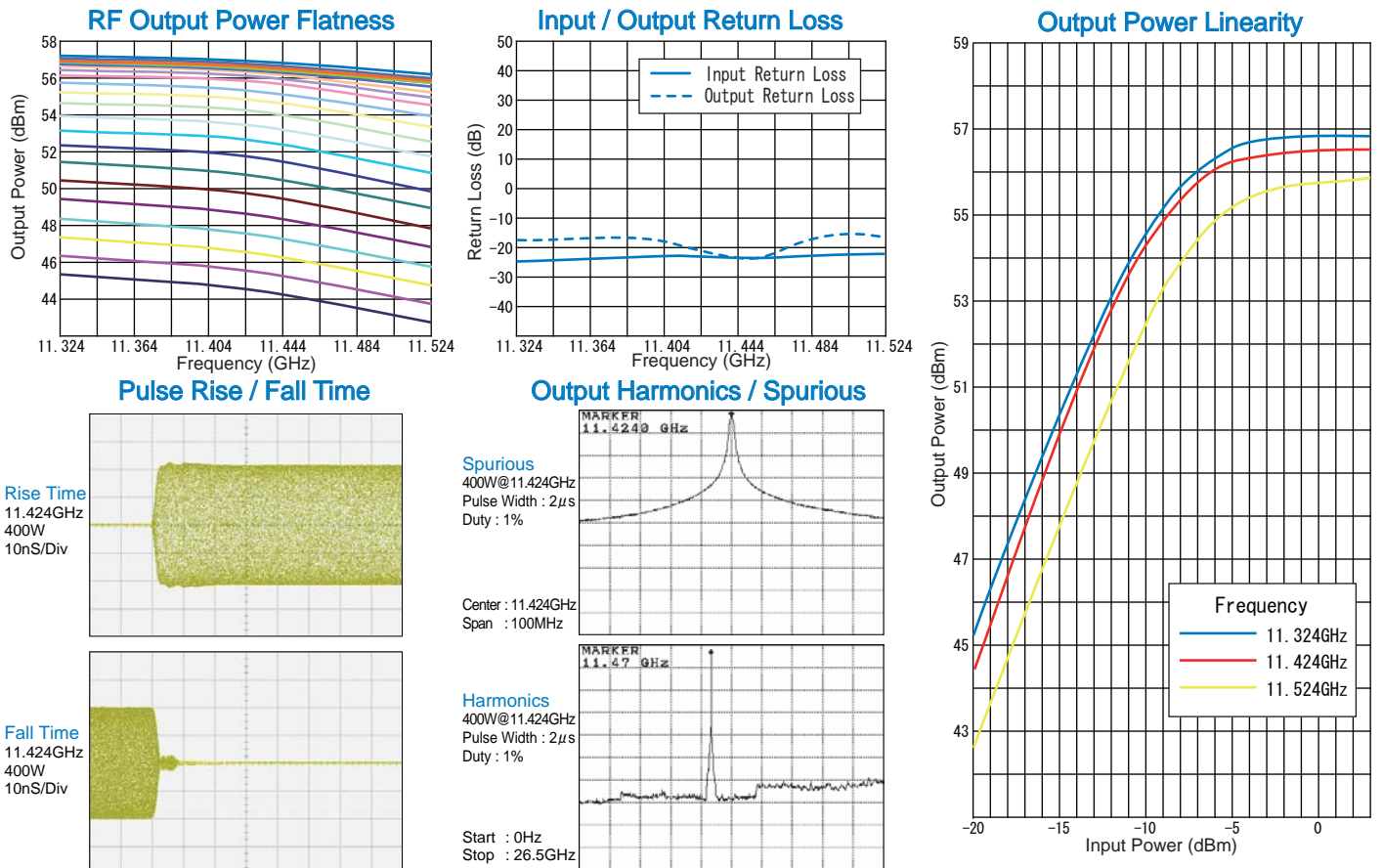

HOW TO ORDER

Model Name
R&K-CGA11424BW200-5757R(P) No Option

R&K reserves the right to make changes in the specifications of or discontinue products at any time without notice. R&K products shall not be used for or in connection with equipment that requires an extremely high level of reliability and safety such as aerospace uses or medical life support equipment. Further, R&K cannot export products to any country for use in military or defense applications.

R&K Company Limited

721-1 Maeda, Fuji-City, Shizuoka-Pref. 416-8577 Japan
Tel : +81-545-31-2600 E-mail : info@rkco.jp
Fax : +81-545-31-1600 URL : http://rk-microwave.com

Measuring Points

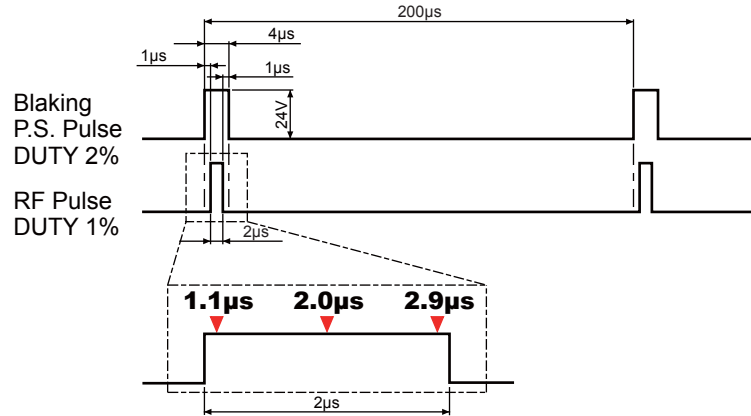

Output Phase Stability v.s. Time

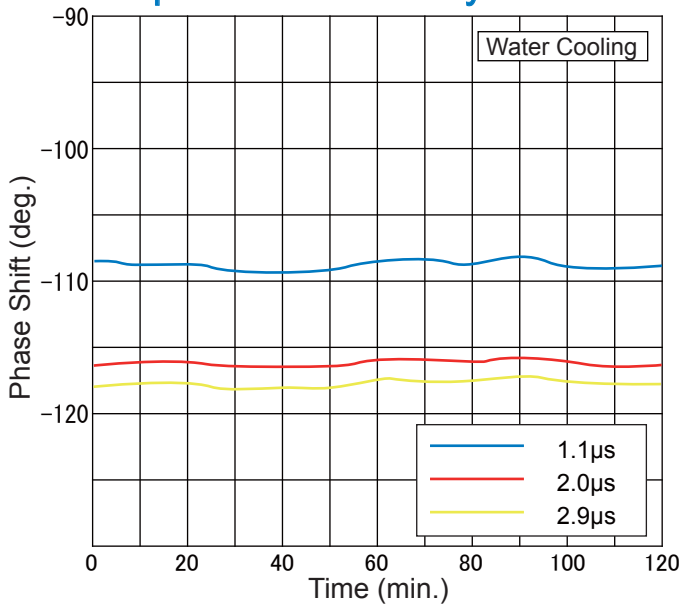

Output Phase Stability v.s. Time

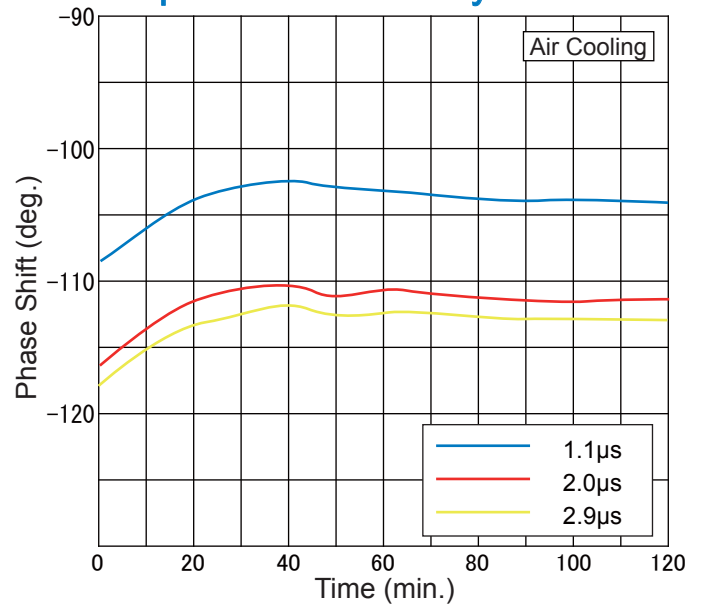

Output Phase Stability v.s. Pout

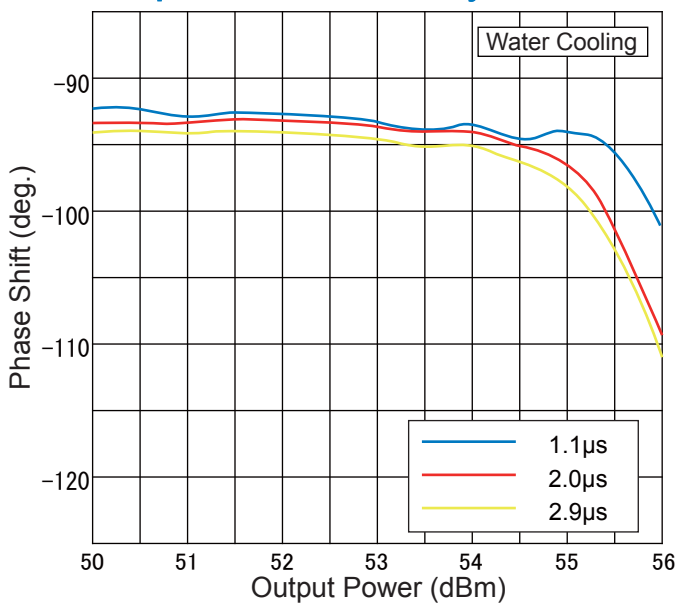

Output Phase Stability v.s. Pout

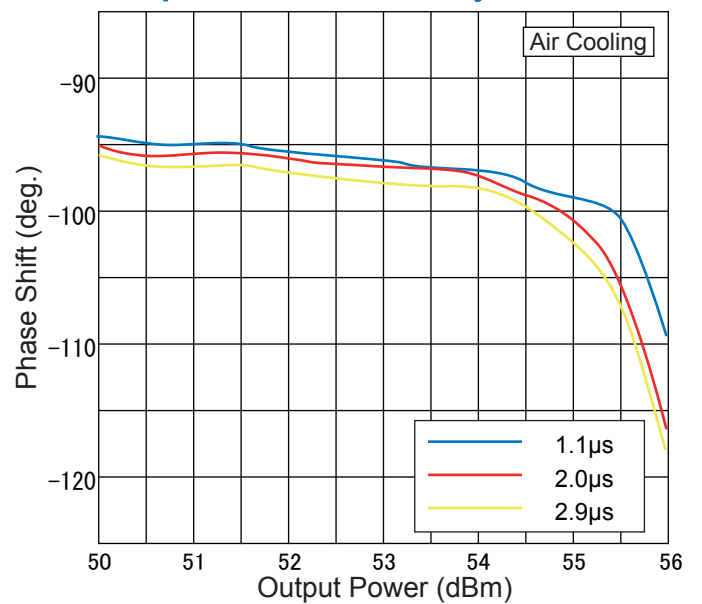

R&K reserves the right to make changes in the specifications of or discontinue products at any time without notice. R&K products shall not be used for or in connection with equipment that requires an extremely high level of reliability and safety such as aerospace uses or medical life support equipment. Further, R&K cannot export products to any country for use in military or defense applications.

R&K Company Limited

721-1 Maeda, Fuji-City, Shizuoka-Pref. 416-8577 Japan
 Tel: +81-545-31-2600 E-mail: info@rkco.jp
 Fax: +81-545-31-1600 URL: http://rk-microwave.com